

## GOLAY COMPLEMENTARY CODES, DOUBLE PULSE REPETITION FREQUENCY TRANSMISSION

I. TROTS, A. NOWICKI, M. LEWANDOWSKI  
J. LITNIEWSKI, W. SECOMSKI

Institute of Fundamental Technological Research  
Polish Academy of Sciences  
Świętokrzyska 21, 00-049 Warszawa, Poland  
e-mail: igor@ippt.gov.pl

*(received June 15, 2006; accepted September 30, 2006)*

This study concerns the development and investigation of a new composing method of short coded sequences and their transmission based on well-known Golay complementary codes and applied compression technique allowing to increase the signal-to-noise ratio (SNR) and penetration. This new method can potentially play important role in examination of superficial structures, e.g. dermatology, ophthalmology, etc.

This paper reports the results of examination of the two pairs 3.5 MHz coded sequences of the same duration: the single 32-bits pair Golay sequences and combined sequences consisting of two 16-bits Golay codes separated in time. The results clearly demonstrate the potential of the combined coded transmission obtaining the  $\text{SNR} = 22.6$  dB that is 2.6 dB higher than for the traditional Golay sequences and it is in case when coded length is two times shorter. For obtaining the same SNR using traditional method the code length should be at least 64 bits long, resulting in the increased dead zone up to 1.4 cm.

**Key words:** Golay complementary sequences, double transmission, dead zone.

### 1. Introduction

Permanent development of the ultrasound technique using the coded excitation signals is connected to technological progress – from the methods of the wave generation to computer programs, which facilitate the measurements as well as analysis of the changes and monitoring of the treatment of disease. Nowadays coded transmission in ultrasonography is dynamically developing – from parametric imaging of bone in the range 0.5–2 MHz, through imaging in classic ultrasonography (3.5–10 MHz) up to imaging in micro ultrasonography (above 20 MHz).

Coded ultrasonography is intensively developed and studied in the last decade. The reason of such interest lies in the properties of the coded transmission: increasing of penetration depth, signal-to-noise ratio improvement, exploring the signal with lower amplitude and improving of the axial resolution moving to the higher frequency range. Nowadays extensively explored coded sequences are: linearly frequency modulated sig-

nals (chirp) and phase-modulated signals like Barker codes and Golay complementary sequences (side-lobe canceling codes).

Within the last few years, the increasing interest in visualization of tissue surface [1] as well as vessel wall research using high frequency ultrasound can be observed among biologists and clinicians. Development of high frequency ultrasound is directed to a new region of application in dermatology and diagnostics of the skin disease as well as lesion treatment. Ultrasonography methods are applied to examine three main skin layers: epidermis, cutis vera and hypodermis. Also, the application of ultrasound diagnostics in ophthalmology is very important as it allows to examine and to diagnose the pathological changes of benign and malicious tumours, cysts, cornea, iris, and other parts of the eye. The one more advantage is that ultrasound allows penetrating into the structure of the atherosclerosis changes in blood vessels.

## 2. Coded excitation in ultrasonography

In comparison to the classic ultrasonography where the short burst pulses are transmitted in coded transmission the longer signals with special shape design are used [6, 7]. As a result the signals with complicated internal construction and exactly defined by time duration are obtained.

Actual research overview and development trend of the coded transmission method in ultrasonography was presented by MISARIDIS [5]. He presented the clinical results by using chirp signal and Golay codes at nominal transducer frequency 4 MHz. The echo data were digitized at a 40 MHz sample rate using 12-bits analog-to-digital acquisition board. All computations were performed with MATLAB® in off-line processing.

KAI LIU *et al.* [3] presented actual development of the coded transmission and its usage in commercial systems. They concentrated on using complementary Golay sequences in ultrasound ophthalmology diagnostic. For that reason the 32-bits Golay coded sequences at nominal transducer frequency 4 MHz were used. The radiofrequency (RF) echo signal was digitized at a 40 MHz sample rate using 10-bits analog-to-digital acquisition board. The author noticed also that the collateral effect of the coded transmission was considerable increase of the dead zone next to the transducer.

The structural scheme for obtaining the impulse response for the applied complementary sequences is shown in Fig. 1.

The impulse response, as shown in Fig. 1, can be write as:

$$C_k = A_k \otimes r_k^A + B_k \otimes r_k^B = A_k \otimes (A_k \times h_k) + B_k \otimes (B_k \times h_k) = 2nh_k,$$

where  $\otimes$  means convolution,  $h_k$  is impulse response of the transducer;  $C_K^A, C_K^B$  are the impulse response of the complementary sequences  $A_k$  and  $B_k$ , respectively.

The final output is  $2n$  times larger than the response to a single impulse; however, the noise is increased by a factor of  $\sqrt{2n}$  ( $\sqrt{n}$  for each correlation and  $\sqrt{2}$  for the addition) [7]. Therefore, an improvement of the SNR in  $\sqrt{2n}$  is obtained in comparison with the single period burst transmission. More realistically, transmitting two sequences per observation time, the SNR improvement factor is actually  $\sqrt{n}$ .

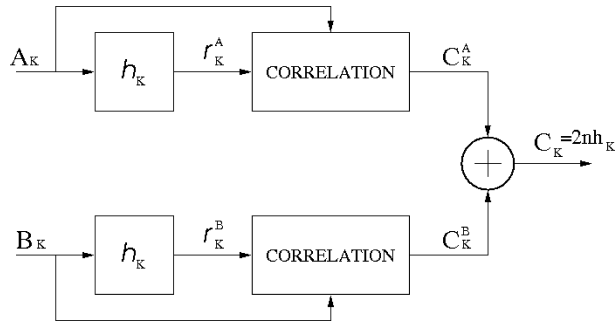

Fig. 1. Impulse response for complementary sequences.

### 3. The Golay complementary sequences

Among the different excitation sequences proposed in ultrasonography, Golay codes evoke more and more interest in comparison to other signals. The reason of that lies in the fact that Golay codes, like no other signals, suppress to zero the amplitude of side-lobes in ideal case. This type of complementary sequences has been introduced by GOLAY [2]. The principle of construction and properties of the Golay complementary sequences are described in [7].

By now the usage of Golay complementary codes was limited by transmitting single pair with later processing (correlation and summing) as shown in Fig. 2.

Figure 2 shows the practical realization of the transmitting Golay coded sequences. As can be easily seen in practice different artifacts are present and because of that the noise elimination and side-lobe cancellation in resulted signal cannot be obtained. And this high noise level can lead to wrong visualization of the examined organs and range ambiguity. The nice method, which can decrease the noise level is using the longer Golay coded sequences i.e. 128 or even 512 bit lengths. Using longer coded sequences is welcome in radar technique or hydrolocation – where information located closely to transducer is not important. In ultrasonography the usage of longer coded sequences is rather limited since it leads to increase of the dead zone that is not accepted in some diagnostic application.

The area closely connected to transducer surface is called dead zone where the multiple reflections have very high amplitude and mask real echoes. The multiple reflections occur in the cupolas of the mechanical heads and on the interface transducer-skin. Theoretically, the dead zone area is equal to the half burst pulse time duration. But in practice the time duration of the burst pulse is calculated from the beginning to moment when the power drops to the  $-3$  dB level, so the dead zone area is assumed to be equal to burst pulse time duration.

Increase of the echo detection using Golay complementary sequences in comparison to short pulse is evident. Experiment shows the two echoes received from reflectors distanced one from other by 1 cm. SNR improving in compressed signal in comparison to direct echoes is about 15 dB.

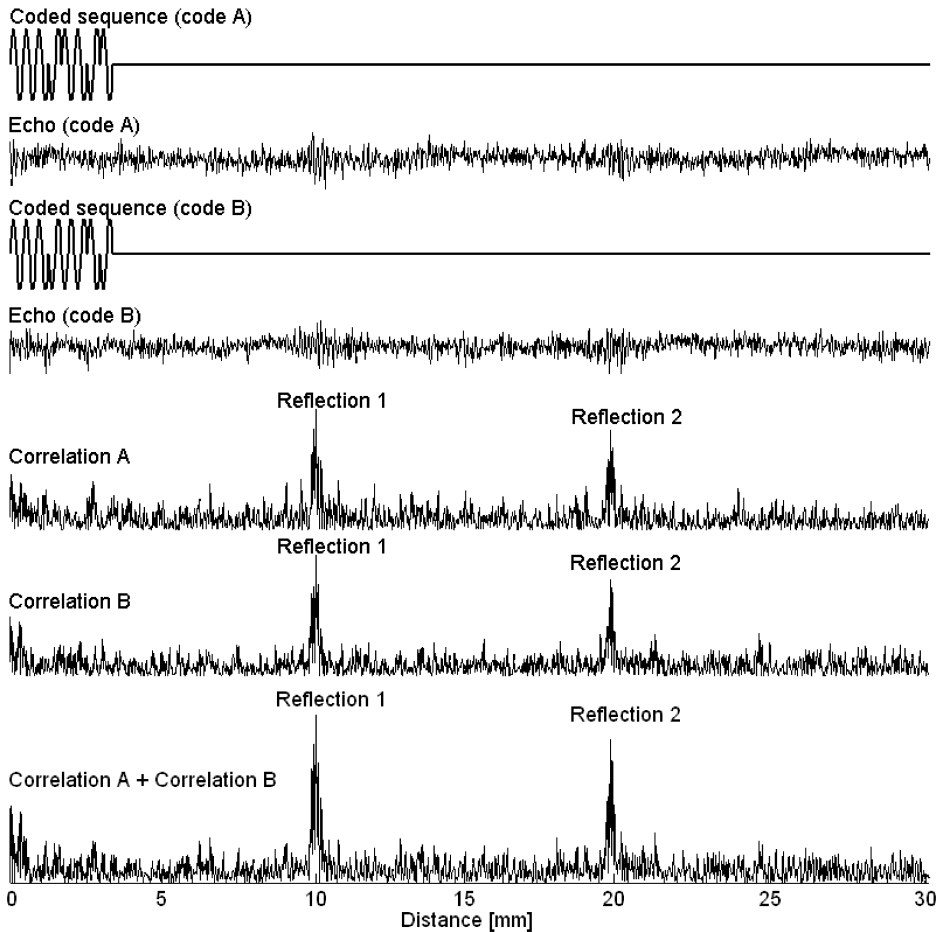

Fig. 2. Correlation and summing of the received echo signals in case of using Golay complementary sequences.

#### 4. Double transmission

Using the double transmission in ultrasonography is supported by growing interest in dermatology, ophthalmology, oncology etc. everywhere, where dead zone plays important role.

Figures 3–5 present the results obtained from the mimicking tissue phantom RMI 405GSX using 32-bits Golay complementary sequences and new method of double transmission using 16-bits Golay sequences.

Figure 3a shows transmitting 32-bits Golay coded sequences at nominal frequency 3.5 MHz and time duration 9.14  $\mu$ s. Figure 3b shows proposed method of the double transmission of 16-bits Golay coded sequences with shorter time duration that is equal 4.57  $\mu$ s. The start time of the second sequence depends on penetration depth that is examined. In the given case, the plot illustrates the examined environment on penetration

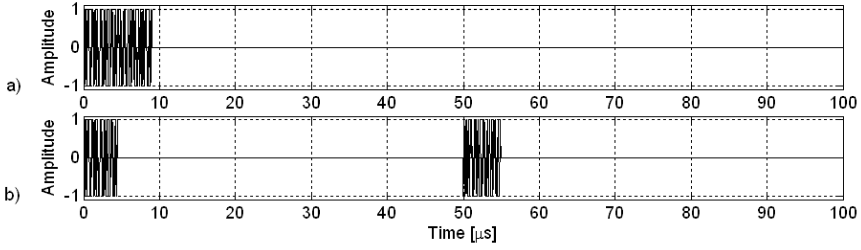

Fig. 3. a) transmission of the 32-bits Golay sequence with time duration 9.14  $\mu\text{s}$ , b) double transmission of the 16-bits Golay sequence with time duration 4.57  $\mu\text{s}$ .

depth up to 4 cm. The starting time of the second sequence can be calculated from:

$$t = \frac{2s}{\nu} = 50 \mu\text{s},$$

where  $s$  is the depth, and  $\nu$  is speed of the ultrasound wave in examined environment and is equal 1540 m/s.

Figure 4 shows reflected RF echo signals obtained from the tissue mimicking phantom RMI 405GSX recorded by oscilloscope Agilent 54641D.

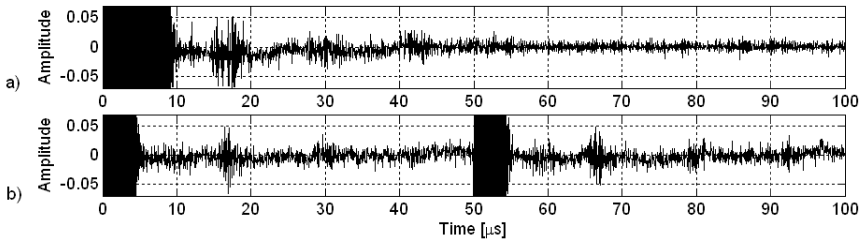

Fig. 4. RF echo signals obtained using: a) 32-bits Golay sequences; b) double trasmission 16-bits Golay sequences.

Using longer coded sequences results in increasing of the dead zone area (Fig. 5a) that increases proportionally to the coded sequences length and inversely to frequency. In the second case (Fig. 5b) the RF echo signal is split into two sequences, next compressed and summed. For objective comparison the SNR is calculated.

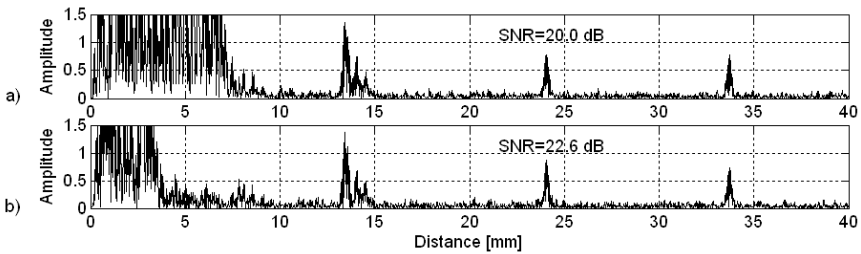

Fig. 5. The resulted RF signals obtained using: a) 32-bits Golay sequences, b) double transmission 16-bits Golay sequences.

Figure 5 shows advantages of the double transmission of the Golay coded sequences (Fig. 5b) in comparison to single Golay coded transmission used heretofore (Fig. 5a). In double transmission case the SNR improves by 2.6 dB. It has to be noted that the coded sequence in double transmission case is 2 times shorter. According to the assumption [7] for getting the SNR equals 22.6 dB the coded sequence length in method used by now must be not less than 64 bits. In that case and for the nominal frequency 3.5 MHz the dead zone area would be 1.4 cm!

## 5. Conclusions

This paper discusses actual study and development trend of the coded transmission method in ultrasonography. One of the important parameter in ultrasound diagnostic is dead zone area that makes the real echoes lying closely to transducer surface unreadable. For that reason the using of the coded sequences in medical ultrasound diagnostic is considerably limited.

The proposed work concerns the development and investigation of a new composing method of short coded sequences and their transmission based on well-known Golay complementary codes. This method allows to increase field of ultrasound diagnostic application where dead zone plays important role, e.g. dermatology, ophthalmology, etc. Also, this composed technique allows to increase the SNR and penetration depth.

The results obtained show the effectiveness of the double transmission and its resistance to the refraction, attenuation, and reflection of ultrasound waves. Choosing of the coded sequences of the appropriate length allows to find the best qualitative solution taking into consideration not only one parameter but few of them, for example side-lobe level and main-lobe width.

The proposed coded method of double transmission can be applied also in standard ultrasonography. Introduction of this proposed coded method in medical ultrasound equipment can increase the effectiveness and quality of the ultrasound diagnostic.

## References

- [1] ALTMAYER P., EL-GAMMAL S., HOFFMANN K., *Ultrasound in dermatology*, Springer-Verlag, Berlin 1992.
- [2] GOLAY M. J. R., *Complementary series*, IRE Trans. Inf. Theory, IT-7, 82–87, April (1961).
- [3] LIU K., PENG Q., WANG X., GAO S., *Vitreous image enhancement in an ophthalmic sonographic imaging system using Golay coded excitation*, J. Ultrasound Med., **24**, 1251–1259 (2005).
- [4] MISARIDIS T., *Ultrasound imaging using coded signals*, Ph.D. Thesis, Center for Fast Ultrasound Imaging, Technical University of Denmark, August 2001.
- [5] MISARIDIS T., PEDERSEN M., JENSEN J., *Clinical use and evaluation of coded excitation in B-mode images*, International IEEE Ultrasonics Symposium, Puerto Rico 2002.
- [6] TROTS I., *Coded excitation and echoes compression in ultrasonography*, Ph.D. Thesis, Ultrasound Department, Institute of Fundamental Technological Research, February 2005.
- [7] TROTS I., NOWICKI A., SECOMSKI W., LITNIEWSKI J., *Golay sequences – side-lobe – canceling codes for ultrasonography*, Archives of Acoustics, **29**, 1, 87–97 (2004).